

INSTALLATION INSTRUCTIONS FOR LIGHT COMMERCIAL SELF-CONTAINED PACKAGED HEATING & COOLING UNIT 3 TON - 6 TON CPC/CPH SERIES

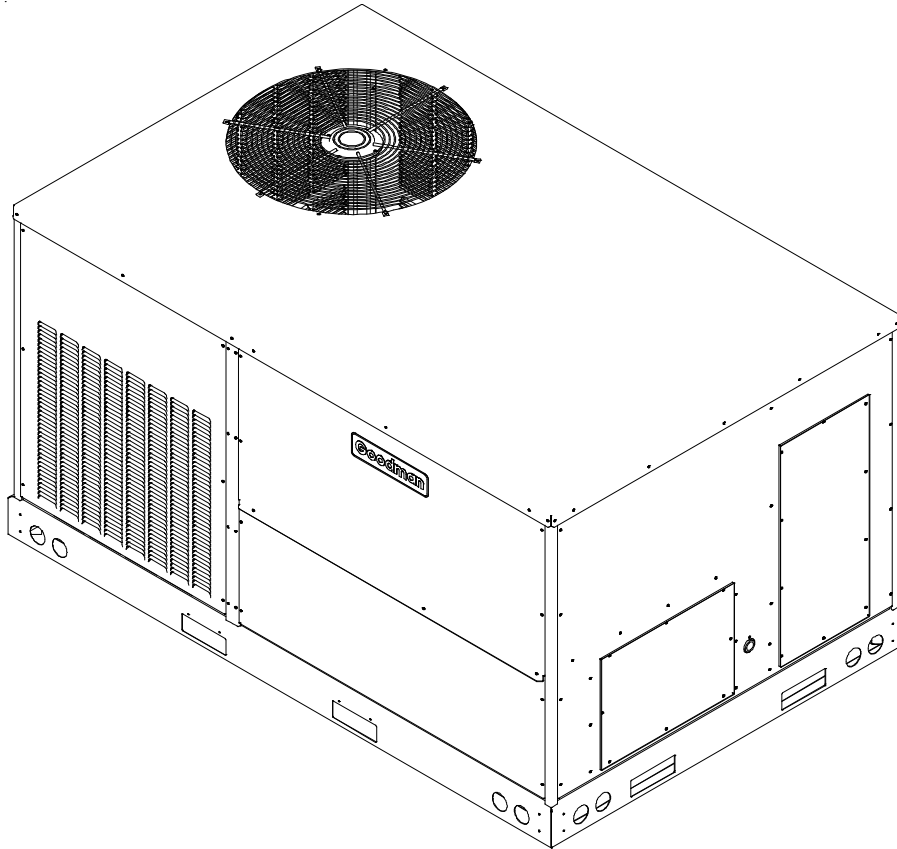

RECOGNIZE THIS SYMBOL AS A SAFETY PRECAUTION.

ATTENTION INSTALLING PERSONNEL

Prior to installation, thoroughly familiarize yourself with this Installation Manual. Observe all safety warnings. During installation or repair, caution is to be observed.

It is your responsibility to install the product safely and to educate the customer on its safe use.

All information contained herein is subject to change without notice.

These installation instructions cover the **outdoor** installation of single package electric heating and cooling units. See the Specification Sheet applicable to your model* for information regarding accessories.

***NOTE:** Please contact your distributor or our website for the applicable Specification Sheet referred to in this manual.



Index

Replacement Parts	2
Safety Instructions	2
General Information	3
Unit Location	4
Clearances	5
Roof Curb Post-Installation Checks	6
Roof Top Duct Connections	6
Rigging Details	6
Electrical Wiring	8
Circulating Air and Filters	10
Venting	10
Condensate Drain Connection	10
Startup, Adjustments, and Checks	10
Heat Pump Operation	13
Air Flow Adjustments	14
Drive Adjustments	15
Motor Sheave Adjustments	15
Maintenance	15
Service	16
Appendix A Blower Performance Tables	17
Direct Drive	17
Standard Down Shot and Horizontal (036)	17
Standard Down Shot and Horizontal (048)	18
Standard CPC/H060 Down Shot	19
Standard CPC/H060 Horizontal	20
Belt Drive	21
Standard Down Shot	21
High Static Down Shot	22
Standard Horizontal	23
High Static Horizontal	24
Appendix B Electrical Data	25
Appendix C Unit Dimensions	27

REPLACEMENT PARTS

ORDERING PARTS

When reporting shortages or damages, or ordering repair parts, give the complete unit model and serial numbers as stamped on the unit's nameplate.

Replacement parts for this appliance are available through your contractor or local distributor. For the location of your nearest distributor, consult the white business pages, the yellow page section of the local telephone book or contact:

CONSUMER AFFAIRS
GOODMAN MANUFACTURING COMPANY, L.P.
7401 SECURITY WAY
HOUSTON, TEXAS 77040
877-254-4729

SAFETY INSTRUCTIONS

TO THE INSTALLER

Before installing this unit, please read this manual to familiarize yourself on the specific items which must be adhered to, including maximum external static pressure to unit, air temperature rise, minimum or maximum CFM and motor speed connections.

Keep this literature in a safe place for future reference.

CAUTION

SHEET METAL PARTS, SCREWS, CLIPS AND SIMILAR ITEMS INHERENTLY HAVE SHARP EDGES, AND IT IS NECESSARY THAT THE INSTALLER AND SERVICE PERSONNEL EXERCISE CAUTION.

WARNING

DO NOT CONNECT TO OR USE ANY DEVICE THAT IS NOT DESIGN CERTIFIED BY GOODMAN FOR USE WITH THIS UNIT. SERIOUS PROPERTY DAMAGE, PERSONAL INJURY, REDUCED UNIT PERFORMANCE AND/OR HAZARDOUS CONDITIONS MAY RESULT FROM THE USE OF SUCH NON-APPROVED DEVICES.

WARNING

THIS PRODUCT CONTAINS OR PRODUCES A CHEMICAL OR CHEMICALS WHICH MAY CAUSE SERIOUS ILLNESS OR DEATH AND WHICH ARE KNOWN TO THE STATE OF CALIFORNIA TO CAUSE CANCER, BIRTH DEFECTS OR OTHER REPRODUCTIVE HARM.

WARNING

TO AVOID PROPERTY DAMAGE, PERSONAL INJURY OR DEATH, DO NOT USE THIS UNIT IF ANY PART HAS BEEN UNDER WATER. IMMEDIATELY CALL A QUALIFIED SERVICE TECHNICIAN TO INSPECT THE FURNACE AND TO REPLACE ANY PART OF THE CONTROL SYSTEM AND ANY GAS CONTROL HAVING BEEN UNDER WATER.

 **WARNING**

THIS UNIT MUST NOT BE USED AS A "CONSTRUCTION HEATER" DURING THE FINISHING PHASES OF CONSTRUCTION ON A NEW STRUCTURE. THIS TYPE OF USE MAY RESULT IN PREMATURE FAILURE OF THE UNIT DUE TO EXTREMELY LOW RETURN AIR TEMPERATURES AND EXPOSURE TO CORROSIVE OR VERY DIRTY ATMOSPHERES.

 **WARNING**

HIGH VOLTAGE!
DISCONNECT ALL POWER BEFORE SERVICING OR INSTALLING THIS UNIT. MULTIPLE POWER SOURCES MAY BE PRESENT. FAILURE TO DO SO MAY CAUSE PROPERTY DAMAGE, PERSONAL INJURY OR DEATH.



 **WARNING**

TO PREVENT THE RISK OF PROPERTY DAMAGE, PERSONAL INJURY, OR DEATH, DO NOT STORE COMBUSTIBLE MATERIALS OR USE GASOLINE OR OTHER FLAMMABLE LIQUIDS OR VAPORS IN THE VICINITY OF THIS APPLIANCE.

 **WARNING**

ONLY INDIVIDUALS MEETING (AT A MINIMUM) THE REQUIREMENTS OF AN "ENTRY LEVEL TECHNICIAN" AS SPECIFIED BY THE AIR-CONDITIONING, HEATING AND REFRIGERATION INSTITUTE (AHRI) MAY USE THIS INFORMATION. ATTEMPTING TO INSTALL OR REPAIR THIS UNIT WITHOUT SUCH BACKGROUND MAY RESULT IN PRODUCT DAMAGE, PERSONAL INJURY OR DEATH.

GENERAL INFORMATION

 **WARNING**

TO PREVENT PROPERTY DAMAGE PERSONAL INJURY OR DEATH, DUE TO FIRE, EXPLOSIONS, SMOKE, SOOT, CONDENSATION, ELECTRIC SHOCK OR CARBON MONOXIDE, THIS UNIT MUST BE PROPERLY INSTALLED, REPAIRED, OPERATED, AND MAINTAINED.

This unit is approved for outdoor installation ONLY. Rated performance is achieved after 72 hours of operation. Rated performance is delivered at the specified airflow. See outdoor unit specification sheet for split system models or product specification sheet for packaged and light commercial models. Specification sheets can be found at www.goodmanmfg.com for Goodman® brand products or www.amana-hac.com for Amana® brand products. Within either website, please select the residential or commercial products menu and then select the submenu for the type of product to be installed, such as air conditioners or heat pumps, to access a list of product pages that each contain links to that model's specification sheet.

To assure that your unit operates safely and efficiently, it must be installed, operated, and maintained in accordance with these installation and operating instructions, all local building codes and ordinances.

EPA REGULATIONS

IMPORTANT: THE UNITED STATES ENVIRONMENTAL PROTECTION AGENCY (EPA) HAS ISSUED VARIOUS REGULATIONS REGARDING THE INTRODUCTION AND DISPOSAL OF REFRIGERANTS IN THIS UNIT. FAILURE TO FOLLOW THESE REGULATIONS MAY HARM THE ENVIRONMENT AND CAN LEAD TO THE IMPOSITION OF SUBSTANTIAL FINES. BECAUSE REGULATIONS MAY VARY DUE TO PASSAGE OF NEW LAWS, WE SUGGEST A CERTIFIED TECHNICIAN PERFORM ANY WORK DONE ON THIS UNIT. SHOULD YOU HAVE ANY QUESTIONS PLEASE CONTACT THE LOCAL OFFICE OF THE EPA.

NATIONAL CODES

This product is designed and manufactured to permit installation in accordance with National Codes. It is the installer's responsibility to install the product in accordance with National Codes and/or prevailing local codes and regulations.

The heating and cooling capacities of the unit should be greater than or equal to the design heating and cooling loads of the area to be conditioned. The loads should be calculated by an approved method or in accordance with ASHRAE Guide or Manual J - Load Calculations published by the Air Conditioning Contractors of America.

Obtain from:

American National Standards Institute
1430 Broadway
New York, NY 10018

System design and installation should also, where applicable, follow information presented in accepted industry guides such as the ASHRAE Handbooks. The manufacturer assumes no responsibility for equipment installed in violation of any code or regulation. The mechanical installation of the packaged roof top units consists of making final connections between the unit and building services; supply and return duct connections; and drain connections (if required). The internal systems of the unit are completely factory-installed and tested prior to shipment.

Units are generally installed on a steel roof mounting curb assembly which has been shipped to the job site for installation on the roof structure prior to the arrival of the unit. The model number shown on the unit's identification plate identifies the various components of the unit such as refrigeration tonnage, heating input and voltage.

Carefully inspect the unit for damage including damage to the cabinetry. Any bolts or screws which may have loosened in transit must be re-tightened. In the event of damage, the receiver should:

1. Make notation on delivery receipt of any visible damage to shipment or container.
2. Notify carrier promptly and request an inspection.
3. In case of concealed damage, carrier should be notified as soon as possible-preferably within 5 days.
4. File the claim with the following supporting documents:

- a. Original Bill of Lading, certified copy, or indemnity bond.
- b. Original paid freight bill or indemnity in lieu thereof.
- c. Original invoice or certified copy thereof, showing trade and other discounts or reductions.
- d. Copy of the inspection report issued by carrier representative at the time damage is reported to the carrier. The carrier is responsible for making prompt inspection of damage and for a thorough investigation of each claim. The distributor or manufacturer will not accept claims from dealers for transportation damage.

NOTE: When inspecting the unit for transportation damage, remove all packaging materials. Recycle or dispose of the packaging material according to local codes.

PRE-INSTALLATION CHECKS

Carefully read all instructions for the installation prior to installing unit. Ensure each step or procedure is understood and any special considerations are taken into account before starting installation. Assemble all tools, hardware and supplies needed to complete the installation. Some items may need to be purchased locally.

UNIT LOCATION

 WARNING
<p>TO PREVENT POSSIBLE EQUIPMENT DAMAGE, PROPERTY DAMAGE, PERSONAL INJURY OR DEATH, THE FOLLOWING BULLET POINTS MUST BE OBSERVED WHEN INSTALLING THE UNIT.</p>

IMPORTANT NOTE: Remove wood shipping rails prior to installation of the unit.

ALL INSTALLATIONS:

IMPORTANT NOTE: If a crankcase heater is used, the unit should be energized 24 hours prior to compressor start up to ensure crankcase heater has sufficiently warmed the compressor. Compressor damage may occur if this step is not followed.

NOTE: Appliance is shipped from factory for vertical duct application.

Proper installation of the unit ensures trouble-free operation. Improper installation can result in problems ranging from noisy operation to property or equipment damages, dangerous conditions that could result in injury or personal property damage and could void the warranty. Give this booklet to the user and explain it's provisions. The user should retain these instructions for future reference.

- For proper operation and condensate drainage, the unit must be mounted level.
- Do not locate the unit in an area where the outdoor air will be frequently contaminated by compounds containing chlorine or fluorine. Common sources of

such compounds include swimming pool chemicals and chlorine bleaches, paint stripper, adhesives, paints, varnishes, sealers, waxes (which are not yet dried) and solvents used during construction and remodeling. Various commercial and industrial processes may also be sources of chlorine/fluorine compounds.

- To avoid possible illness or death of the building occupants, do NOT locate outside air intake device (economizer, manual fresh air intake, motorized fresh air intake) too close to an exhaust outlet, gas vent termination, or plumbing vent outlet. For specific distances required, consult local codes.
- Allow minimum clearances from the enclosure for fire protection, proper operation, and service access (see Unit Clearances). These clearances must be permanently maintained.
- When the unit is heating, the temperature of the return air entering the unit must be between 50°F and 100°F.

GROUND LEVEL INSTALLATIONS ONLY:

- When the unit is installed on the ground adjacent to the building, a level concrete (or equal) base is recommended. Prepare a base that is 3" larger than the package unit footprint and a minimum of 3" thick.
- The base should also be located where no runoff of water from higher ground can collect in the unit.

ROOF TOP INSTALLATIONS ONLY:

- To avoid possible property damage or personal injury, the roof must have sufficient structural strength to carry the weight of the unit(s) and snow or water loads as required by local codes. Consult a structural engineer to determine the weight capabilities of the roof.
- The unit may be installed directly on wood floors or on Class A, Class B, or Class C roof covering material.
- To avoid possible personal injury, a safe, flat surface for service personnel should be provided.
- Adequate clearances from the unit to any adjacent public walkways, adjacent buildings, building openings or openable windows must be maintained in accordance with National Codes.

UNIT PRECAUTIONS

- Do not stand or walk on the unit.
- Do not drill holes anywhere in panels or in the base frame of the unit. Unit access panels provide structural support.
- Do not remove any access panels until unit has been installed on roof curb or field supplied structure.
- Do not roll unit across finished roof without prior approval of owner or architect.
- Do not skid or slide on any surface as this may damage unit base. The unit must be stored on a flat, level surface. Protect the condenser coil because it is easily damaged.

ROOF CURB INSTALLATIONS ONLY:

Curb installations must comply with local codes and should be done in accordance with the established guidelines of the National Roofing Contractors Association.

Proper unit installation requires that the roof curb be firmly and permanently attached to the roof structure. Check for adequate fastening method prior to setting the unit on the curb.

Full perimeter roof curbs are available from the factory and are shipped unassembled. Field assembly, squaring, leveling and mounting on the roof structure are the responsibility of the installing contractor. All required hardware necessary for the assembly of the sheet metal curb is included in the curb accessory.



WARNING

TO PREVENT POSSIBLE EQUIPMENT DAMAGE, PROPERTY DAMAGE, PERSONAL INJURY OR DEATH, THE FOLLOWING BULLET POINTS MUST BE OBSERVED WHEN INSTALLING THE UNIT.

- Sufficient structural support must be determined prior to locating and mounting the curb and package unit.
- Ductwork must be constructed using industry guidelines. The duct work must be placed into the roof curb before mounting the package unit. Our full perimeter curbs include duct connection frames to be assembled with the curb. Cantilevered type curbs are not available from the factory.
- Curb insulation, cant strips, flashing and general roofing material are furnished by the contractor.

The curbs must be supported on parallel sides by roof members. The roof members must not penetrate supply and return duct opening areas as damage to the unit might occur.

NOTE: The unit and curb accessories are designed to allow vertical duct installation before unit placement. Duct installation after unit placement is not recommended.



CAUTION

ALL CURBS LOOK SIMILAR. TO AVOID INCORRECT CURB POSITIONING, CHECK JOB PLANS CAREFULLY AND VERIFY MARKINGS ON CURB ASSEMBLY. INSTRUCTIONS MAY VARY IN CURB STYLES AND SUPERSEDES INFORMATION SHOWN.

See the manual shipped with the roof curb for assembly and installation instructions.

CLEARANCES

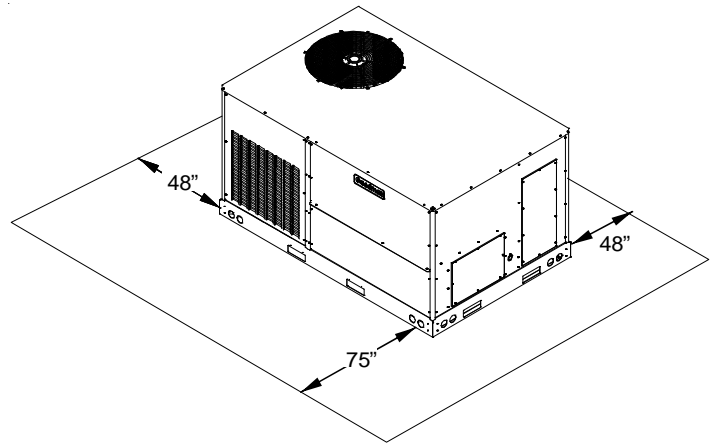

UNIT CLEARANCES

Adequate clearance around the unit should be kept for safety, service, maintenance, and proper unit operation. A total clearance of 75" on the main control panel side of the unit is recommended to facilitate possible fan shaft, coil, and electric heat. A clearance of 48" is recommended on all other sides of the unit to facilitate possible compressor removal, to allow service access and to insure proper ventilation and condenser airflow. The unit must not be installed beneath any obstruction. The unit should be installed remote from all building exhausts to inhibit ingestion of exhaust air into the unit fresh air intake.

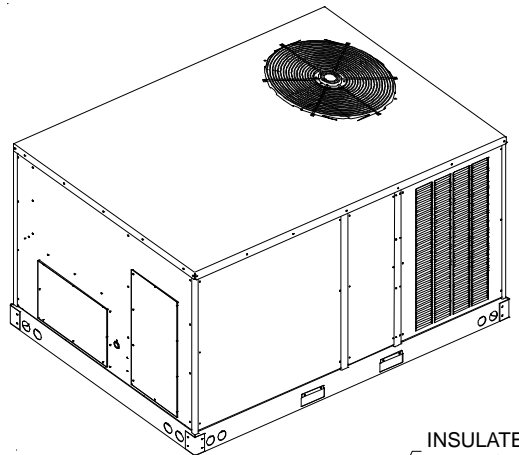

INSULATED
PANELS

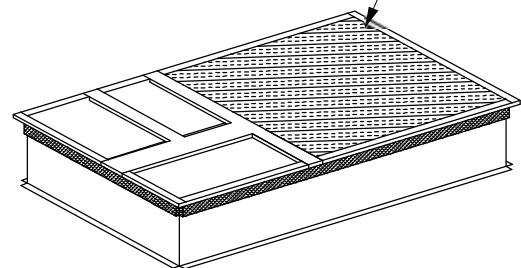

ROOF CURB INSTALLATION

ROOF CURB POST-INSTALLATION CHECKS

After installation, check the top of the curb, duct connection frame and duct flanges to make sure gasket has been applied properly. Gasket should be firmly applied to the top of the curb perimeter, duct flanges and any exposed duct connection frame. If gasket is loose, reapply using strong weather resistant adhesive.

PROTRUSION

Inspect curb to ensure that none of the utility services (electric) routed through the curb protrude above the curb.



CAUTION

IF PROTRUSIONS EXIST, DO NO ATTEMPT TO SET UNIT ON CURB.

ROOF TOP DUCT CONNECTIONS

Install all duct connections on the unit before placing the unit on rooftop.

HORIZONTAL DISCHARGE

For horizontal discharge, remove the supply and return duct covers and place them over the vertical discharge return and supply openings. Install with insulation facing up, using the longer screws provided in the literature package.

Ensure that the top of the duct connection frame is flush with the top of the roof curb.

Flexible duct connectors between the unit and ducts are recommended. Insulate and weatherproof all external ductwork and joints as required and in accordance with local codes.

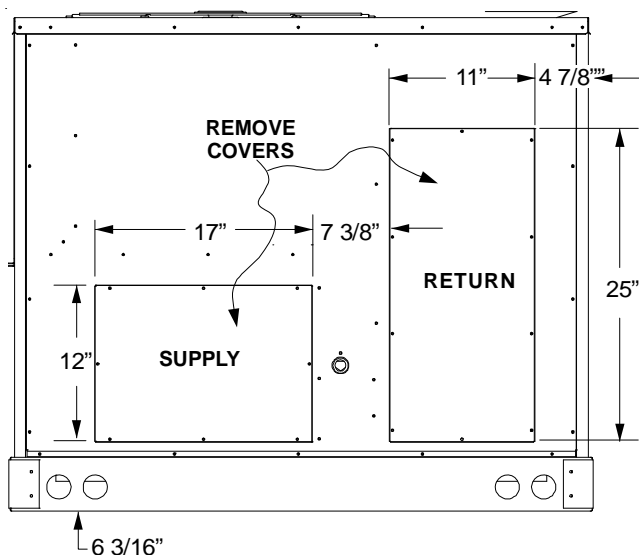

HORIZONTAL DISCHARGE DUCT CONNECTIONS

RIGGING DETAILS



WARNING

TO PREVENT PROPERTY DAMAGE, THE UNIT SHOULD REMAIN IN AN UPRIGHT POSITION DURING ALL RIGGING AND MOVING OPERATIONS. TO FACILITATE LIFTING AND MOVING WHEN A CRANE IS USED, PLACE THE UNIT IN AN ADEQUATE CABLE SLING.



CAUTION

IF UNITS ARE LIFTED TWO AT A TIME, THE FORK HOLES ON THE CONDENSER END OF THE UNIT MUST NOT BE USED. MINIMUM FORK LENGTH IS 42" TO PREVENT DAMAGE TO THE UNIT; HOWEVER, 48" IS RECOMMENDED.

Provisions for forks have been included in the unit base frame. No other fork locations are approved.



WARNING

TO PREVENT POSSIBLE EQUIPMENT DAMAGE, PROPERTY DAMAGE, PERSONAL INJURY OR DEATH, THE FOLLOWING BULLET POINTS MUST BE OBSERVED WHEN INSTALLING THE UNIT.

- Unit must be lifted by the four lifting holes located at the base frame corners.
- Lifting cables should be attached to the unit with shackles.
- The distance between the crane hook and the top of the unit must not be less than 60".
- Two spreader bars must span over the unit to prevent damage to the cabinet by the lift cables. Spreader bars must be of sufficient length so that cables do not come in contact with the unit during transport. Remove wood struts mounted beneath unit base frame before setting unit on roof curb. These struts are intended to protect unit base frame from fork lift damage. Removal is accomplished by extracting the sheet metal retainers and pulling the struts through the base of the unit. Refer to rigging label on the unit.

Important: If using bottom discharge with roof curb, ductwork should be attached to the curb prior to installing the unit. Ductwork dimensions are shown in Roof Curb Installation Instructions.

Refer to the Roof Curb Installation Instructions for proper curb installation. Curbing must be installed in compliance with the National Roofing Contractors Association Manual.

Lower unit carefully onto roof mounting curb. While rigging unit, center of gravity will cause condenser end to be lower than supply air end.

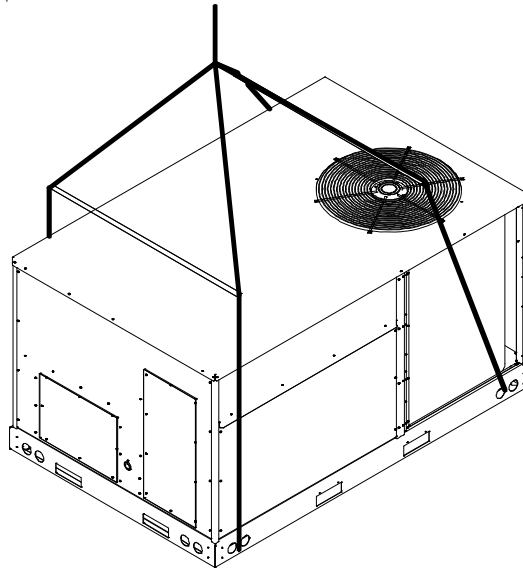

To assist in determining rigging requirements, unit weights are shown as follows:

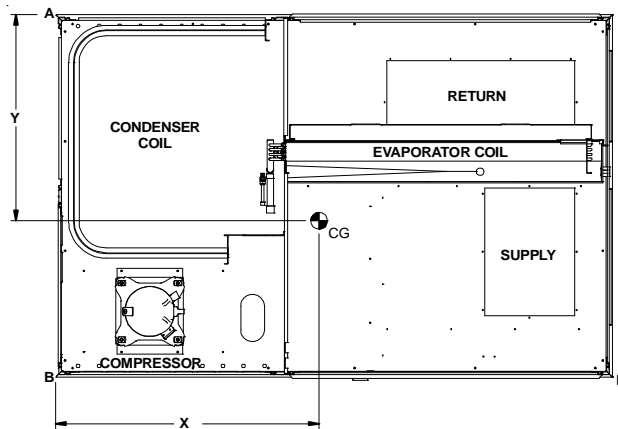

CORNER & CENTER OF GRAVITY LOCATIONS

Model	X (in)	Y (in)	Shipping Weight (lbs)	Operating Weight (lbs)	Corner Weights (lbs)			
					A	B	C	D
CPC036*	35	27	525	500	115	150	105	130
CPC048*	35	27	560	535	125	160	110	140
CPC060*	35	27	605	580	135	170	120	155
CPC072*	35	27	665	640	150	190	130	170
CPH036*	34	28	605	580	130	180	110	155
CPH048*	34	28	610	585	135	185	115	155
CPH060*	34	28	615	590	135	185	115	160
CPH072*	34	28	675	650	145	205	125	175

* Weights shown are belt drive with no accessories.

CAUTION

TO PREVENT SEVERE DAMAGE TO THE BOTTOM OF THE UNIT, DO NOT FORK LIFT UNIT AFTER WOOD STRUTS HAVE BEEN REMOVED.

Bring condenser end of unit into alignment with the curb. With condenser end of the unit resting on curb member and using curb as a fulcrum, lower opposite end of the unit until entire unit is seated on the curb. When a rectangular cantilever curb is used, care should be taken to center the unit. Check for proper alignment and orientation of supply and return openings with duct.

RIGGING REMOVAL

CAUTION

TO PREVENT DAMAGE TO THE UNIT, DO NOT ALLOW CRANE HOOKS AND SPREADER BARS TO REST ON THE ROOF OF THE UNIT.

Remove spreader bars, lifting cables and other rigging equipment.

ELECTRICAL WIRING

WARNING

HIGH VOLTAGE!
DISCONNECT ALL POWER BEFORE SERVICING OR INSTALLING THIS UNIT. MULTIPLE POWER SOURCES MAY BE PRESENT. FAILURE TO DO SO MAY CAUSE PROPERTY DAMAGE, PERSONAL INJURY OR DEATH.



WARNING

HIGH VOLTAGE!
TO AVOID PERSONAL INJURY OR DEATH DUE TO ELECTRICAL SHOCK, DO NOT TAMPER WITH FACTORY WIRING. THE INTERNAL POWER AND CONTROL WIRING OF THESE UNITS ARE FACTORY-INSTALLED AND HAVE BEEN THOROUGHLY TESTED PRIOR TO SHIPMENT. CONTACT YOUR LOCAL REPRESENTATIVE IF ASSISTANCE IS REQUIRED.



CAUTION

TO PREVENT DAMAGE TO THE WIRING, PROTECT WIRING FROM SHARP EDGES. FOLLOW NATIONAL ELECTRICAL CODE AND ALL LOCAL CODES AND ORDINANCES. DO NOT ROUTE WIRES THROUGH REMOVABLE ACCESS PANELS.

CAUTION

CONDUIT AND FITTINGS MUST BE WEATHER-TIGHT TO PREVENT WATER ENTRY INTO THE BUILDING.

For unit protection, use a fuse or HACR circuit breaker that is in excess of the circuit ampacity, but less than or equal to the maximum overcurrent protection device. DO NOT EXCEED THE MAXIMUM OVERCURRENT DEVICE SIZE SHOWN ON UNIT DATA PLATE.

All line voltage connections must be made through weather-proof fittings. All exterior power supply and ground wiring must be in approved weatherproof conduit.

The main power supply wiring to the unit and low voltage wiring to accessory controls must be done in accordance with these instructions, the latest edition of the National Electrical Code (ANSI/NFPA 70), and all local codes and ordinances. All field wiring shall conform with the temperature limitations for Type T wire (63°F/35°C rise).

The unit is factory wired for the voltage shown on the unit's data plate. Refer to model nomenclature in Appendix D for voltage requirement for your unit.

NOTE: If supply voltage is 208V, lead on primary of transformer must be moved from the 230V to the 208V tap. Refer to wiring diagram on unit for details.

Main power wiring should be sized for the minimum wire ampacity shown on the unit's data plate. Size wires in accordance with the ampacity tables in Article 310 of the National Electrical Code. If long wires are required, it may be necessary to increase the wire size to prevent excessive voltage drop. Wires should be sized for a maximum of 3% voltage drop.

CAUTION

TO AVOID PROPERTY DAMAGE OR PERSONAL INJURY DUE TO FIRE, USE ONLY COPPER CONDUCTORS.

CAUTION

LABEL ALL WIRES PRIOR TO DISCONNECTION WHEN SERVICING CONTROLS. WIRING ERRORS CAN CAUSE IMPROPER AND DANGEROUS OPERATION. VERIFY PROPER OPERATION AFTER SERVICING.

NOTE: A weather-tight disconnect switch, properly sized for the unit total load, must be field installed. An external field supplied disconnect may be mounted on the exterior panel.

Ensure the data plate is not covered by the field-supplied disconnect switch.

- Some disconnect switches are not fused. Protect the power leads at the point of distribution in accordance with the unit's data plate.
- The unit must be electrically grounded in accordance with local codes or, in the absence of local codes, with the latest edition of the National Electrical Code (ANSI-NFPA 70). A ground lug is provided for this purpose. Size grounding conductor in accordance with Table 250-95 of the National Electrical Code. Do not use the ground lug for connecting a neutral conductor.
- Remove plug in panel located at the condenser end of unit and route conduit to control box. Remove plug in control box and connect power wiring to the contactor closest to the entrance. If Single Point kit is used, refer to Installation Instructions supplied with kit.

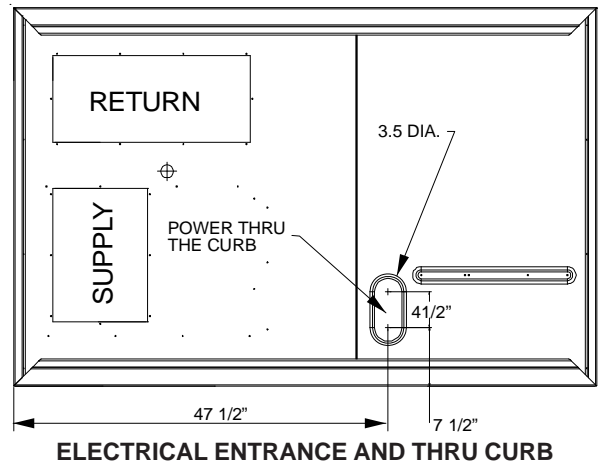
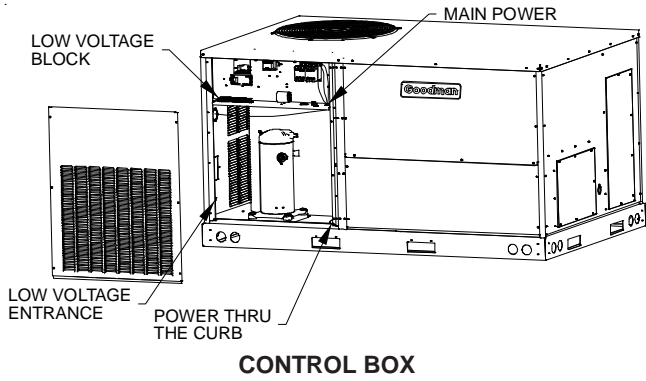

WARNING

FAILURE OF UNIT DUE TO OPERATION ON IMPROPER LINE VOLTAGE OR WITH EXCESSIVE PHASE UNBALANCE CONSTITUTES PRODUCT ABUSE AND WILL VOID YOUR WARRANTY AND MAY CAUSE SEVERE DAMAGE TO THE UNIT ELECTRICAL COMPONENTS.

Areas Without Convenience Outlet

It is recommended that an independent 115V power source be brought to the vicinity of the roof top unit for portable lights and tools used by the service mechanic.

UNITS INSTALLED ON ROOF TOPS

Main power and low voltage wiring may enter the unit through the condenser end or through the roof curb. Install conduit connectors at the desired entrance locations. External connectors must be weatherproof. All holes in the unit base must be sealed (including those around conduit nuts) to prevent water leakage into building. All required conduit and fittings are to be field supplied.

Supply voltage to roof top unit must not vary by more than 10% of the value indicated on the unit's data plate. Phase voltage unbalance must not exceed 2%. Contact your local power company for correction of improper voltage or phase unbalance.

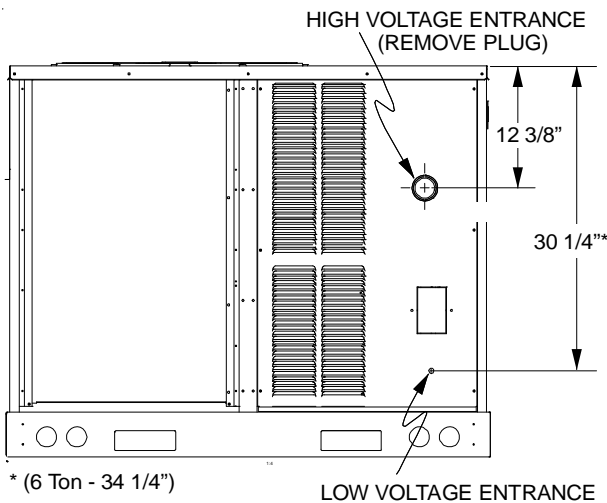

LOW VOLTAGE CONTROL WIRING

1. A 24V thermostat must be installed for unit operation. It may be purchased with the unit or field -supplied. Thermostats may be programmable or electromechanical as required.
2. Locate thermostat or remote sensor in the conditioned space where it will sense average temperature. Do not locate the device where it may be directly exposed to supply air, sunlight or other sources of heat. Follow installation instructions packaged with the thermostat.
3. Use #18 AWG wire for 24V control wiring runs not exceeding 75 feet. Use #16 AWG wire for 24V control wiring runs not exceeding 125 feet. Use #14 AWG wire for 24V control wiring runs not exceeding 200 feet. Low voltage wiring may be National Electrical Code (NEC) Class 2 where permitted by local codes.
4. Route thermostat wires from sub-base terminals to the unit. Control wiring should enter through the condenser panel opening indicated in "Electrical Entrance Locations" figure. Connect thermostat and any accessory wiring to low voltage terminal block TB1 in the main control box.

NOTE: Field-supplied conduit may need to be installed depending on unit/curb configuration. Use #18 AWG solid conductor wire whenever connecting thermostat wires to terminals on sub-base. DO NOT use larger than #18 AWG wire. A transition to #18 AWG wire may be required before entering thermostat sub-base.

TERMINAL	THERMOSTAT
Red	R (24V)
Green	G (Fan)
Orange	O (Rev. Valve)
White	W1 (Heat, 2nd)*
Brown	W2 (Heat 3rd)*
Yellow	Y (Cool)
C (Blue)	C (Common)

*Optional field installed heat connections

CPC/H 036 THROUGH 072

CIRCULATING AIR AND FILTERS

DUCTWORK

The supply duct from the unit through a wall may be installed without clearance. However, minimum unit clearances must be maintained (see "Clearances" section). The supply duct should be provided with an access panel large enough to inspect the air chamber downstream of the heat exchanger. A cover should be tightly attached to prevent air leaks.

Ductwork dimensions are shown in the roof curb installation manual.

If desired, supply and return duct connections to the unit may be made with flexible connections to reduce possible unit operating sound transmission.

VENTING

NOTE: Venting is self-contained.

CONDENSATE DRAIN CONNECTION

CONDENSATE DRAIN CONNECTION

A 3/4" NPT drain connection is supplied for condensate piping. An external trap must be installed for proper condensate drainage.

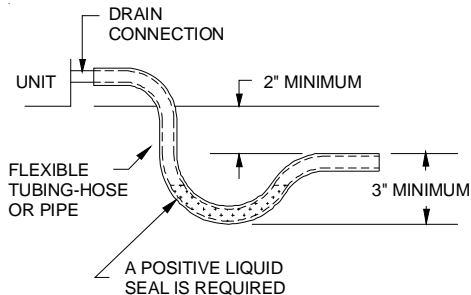

Drain Connection

Install condensate drain trap as shown. Use 3/4" drain line and fittings or larger. Do not operate without trap.

HORIZONTAL DRAIN

Drainage of condensate directly onto the roof may be acceptable; refer to local code. It is recommended that a small drip pad of either stone, mortar, wood or metal be provided to prevent any possible damage to the roof.

CLEANING

Due to the fact that drain pans in any air conditioning unit will have some moisture in them, algae and fungus will grow due to airborne bacteria and spores. Periodic cleaning is necessary to prevent this build-up from plugging the drain.

STARTUP, ADJUSTMENTS, AND CHECKS

WARNING

HIGH VOLTAGE!

TO AVOID PERSONAL INJURY OR DEATH DUE TO ELECTRICAL SHOCK, BOND THE FRAME OF THIS UNIT TO THE BUILDING ELECTRICAL GROUND BY USE OF THE GROUNDING TERMINAL PROVIDED OR OTHER ACCEPTABLE MEANS. DISCONNECT ALL POWER BEFORE SERVICING OR INSTALLING THIS UNIT.



PRE-STARTUP INSTRUCTIONS

CAUTION

TO PREVENT PROPERTY DAMAGE OR PERSONAL INJURY, Do NOT START THE UNIT UNTIL ALL NECESSARY PRE-CHECKS AND TESTS HAVE BEEN PERFORMED.

Prior to the beginning of Startup, Adjustments, and Checks procedures, the following steps should be completed in the building.

THERMOSTAT. Set the thermostat in the conditioned space at a point at least 10°F below zone temperature. Set the thermostat system switch on COOL and the fan switch on AUTO.

NIGHT SETBACK THERMOSTAT (OPTIONAL). Set thermostat at a point at least 10°F below zone temperature.

WARNING

MOVING MACHINERY HAZARD!

TO PREVENT POSSIBLE PERSONAL INJURY OR DEATH, DISCONNECT POWER TO THE UNIT AND PADLOCK IN THE "OFF" POSITION BEFORE SERVICING FANS.

HEATING STARTUP

On new installations, or if a major component has been replaced, the operation of the unit must be checked.

Check unit operation as outlined in the following instructions. If any sparking, odors, or unusual sounds are encountered, shut off electrical power and recheck for wiring errors, or obstructions in or near the blower motors. **Duct covers must be removed before operating unit.**

The Startup, Adjustments, and Checks procedure provides a step-by-step sequence which, if followed, will assure the proper startup of the equipment in the minimum amount of time. Air balancing of duct system is not considered part of this procedure. However, it is an important phase of any air conditioning system startup and should be performed upon completion of the Startup, Adjustments, and Checks procedure. The Startup, Adjustments, and Checks procedure at outside ambients below 55°F should be limited to a readiness check of the refrigeration system with the required final check and calibration left to be completed when the outside ambient rises above 55°F.

TOOLS REQUIRED

Refrigeration gauge and manifold
Voltmeter
Clamp-on ammeter
Ohmmeter
Test lead
(Minimum #16 AWG with insulated alligator clips)
Air temperature measuring device
General refrigeration mechanics' tools

TEMPORARY HEATING OR COOLING

If the unit is to be used for temporary heating or cooling, a "Startup, Adjustments, and Checks" must first be performed in accordance with this manual. Failure to comply with this requirement will void the warranty. **After** the machines are used for temporary heating or cooling, inspect the coils, fans, and motors for unacceptable levels of construction dust and dirt and install new filters.

CONTRACTOR RESPONSIBILITY

The installing contractor must be certain that:

- All supply and return air ductwork is in place and corresponds with installation instructions.
- All thermostats are mounted and wired in accordance with installation instructions.
- All electric power, all gas, hot water or steam line connections, and the condensate drain installation have been made to each unit on the job. These main supply lines must be functional and capable of operating all units simultaneously.

ROOF CURB INSTALLATION CHECK

Inspect the roof curb for correct installation. The unit and curb assembly should be level. Inspect the flashing of the roof mounting curb to the roof, especially at the corners, for good workmanship. Also check for leaks around gaskets. Note any deficiencies in a separate report and forward to the contractor.

OBSTRUCTIONS, FAN CLEARANCE AND WIRING

Remove any extraneous construction and shipping materials that may be found during this procedure. Rotate all fans manually to check for proper clearances and that they rotate freely. Check for bolts and screws that may have jarred loose during shipment to the jobsite. Retighten if necessary. Retighten all electrical connections.

PRE-STARTUP PRECAUTIONS

It is important to your safety that the unit has been properly grounded during installation. Check ground lug connection in main control box for tightness prior to closing circuit breaker or disconnect switch. Verify that supply voltage on line side of disconnect agrees with voltage on unit identification plate and is within the utilization voltage range as indicated in Appendix C Electrical Data.

System Voltage - That nominal voltage value assigned to a circuit or system for the purpose of designating its voltage class.

Nameplate Voltage - That voltage assigned to a piece of equipment for the purpose of designating its voltage class and for the purpose of defining the minimum and maximum voltage at which the equipment will operate.

Utilization Voltage - The voltage of the line terminals of the equipment at which the equipment must give fully satisfactory performance. Once it is established that supply voltage will be maintained within the utilization range under all system conditions, check and calculate if an unbalanced condition exists between phases. Calculate percent voltage unbalance as follows:

Three Phase Models Only

$$3) \text{ PERCENT VOLTAGE UNBALANCE} = 100 \times \frac{2) \text{ MAXIMUM VOLTAGE DEVIATIONS FROM AVERAGE VOLTAGE}}{1) \text{ AVERAGE VOLTAGE}}$$

HOW TO USE THE FORMULA:

EXAMPLE: With voltage of 220, 216, and 213

1) Average Voltage = $220+216+213=649 / 3 = 216$

2) Maximum Voltage Deviations from Average Voltage = $220 - 216 = 4$

3) Percent Voltage Unbalance = $100 \times \frac{4}{216} = \frac{400}{216} = 1.8\%$

Percent voltage unbalance **MUST NOT** exceed 2%.

FIELD DUCT CONNECTIONS

Verify that all duct connections are tight and that there is no air bypass between supply and return.

FILTER SECTION CHECK

Remove filter section access panels and check that filters are properly installed. Note airflow arrows on filter frames.

BELT DRIVE MODELS ONLY

BEARING CHECK

Prior to energizing any fans, check and make sure that all setscrews are tight so that bearings are properly secured to shafts.

For heat pump units, the airflow must be adjusted so that the air temperature rise falls within the ranges given stated on Data Plate (see Appendix A - Blower Performance).

TENSION AND ALIGNMENT ADJUSTMENT

Correct belt tension is very important to the life of your belt. Too loose a belt will shorten its life; too tight, premature motor and bearing failure will occur. Check you belt drive for adequate "run-in" belt tension by measuring the force required to deflect the belt at the midpoint of the span length. Belt tension force can be measured using a belt tension gauge, available through most belt drive manufacturers.

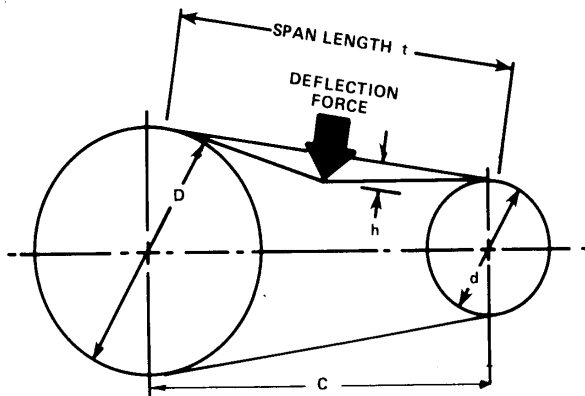

- t = Span length, inches
- C = Center distance, inches
- D = Larger sheave diameter, inches
- d = Smaller sheave diameter, inches
- h = Deflection height, inches

DRIVE BELT TENSION ADJUSTMENT

TYPE		SHEAVE DIAMETER (in)	DEFLECTION FORCE (lbs)		DEFLECTION (in)
BELT	DRIVE		Used	New	
A, AX	Standard	3.0 to 4.0	4.2 ± .5	5.5 ± .5	0.313

RECOMMENDED POUNDS OF FORCE PER BELT

New V-belts will drop rapidly during the first few hours of use. Check tension frequently during the first 24 hours of operation. Tension should fall between the minimum and maximum force. To determine the deflection distance from a normal position, measure the distance from sheave to sheave using a straightedge or a cord. This is your reference line. On multiple belt drives, an adjacent undeflected belt can be used as a reference.

EVAPORATOR FAN ROTATION CHECK (THREE PHASE MODELS ONLY)

Check that fan rotates counter-clockwise when viewed from the drive side of unit and in accordance with rotation arrow shown on blower housing. If it does not, reverse the two incoming power cables. In this case, repeat bearing check.

Do not attempt to change load side wiring. Internal wiring assures all motors and compressors will rotate in correct direction once evaporator fan motor rotation check has been made.

ELECTRICAL INPUT CHECK

Make preliminary check of evaporator fan ampere draw and verify that motor nameplate amps are not exceeded. A final check of amp draw should be made upon completion of air balancing of the duct system (see Appendix B).

REFRIGERATION SYSTEM CHECKS

Ensure the hold-down bolts on the compressor are secure and have not vibrated loose during shipment. Check that vibration grommets have been installed. Visually check all pip-

ing and clamps. The entire refrigeration system has been factory charged and tested, making it unnecessary to field charge. Factory charges are shown on the unit nameplate.

Install service manifold hoses. Gauges should read saturation pressure corresponding to ambient temperature. Charge should be checked to obtain 12° to 15° of sub-cooling per system (i.e. compressor circuits).

START-UP PROCEDURE AND CHECKLIST

Begin with power turned off at all disconnects.

1. Turn thermostat system switch to "Cool," and fan switch to "Auto" and turn temperature setting as high as it will go.
2. Inspect all registers and set them to the normal open position.
3. Turn on the electrical supply at the disconnect.
4. Turn the fan switch to the "ON" position. The blower should operate after a 7 second delay.
5. Turn the fan switch to "Auto" position. The blower should stop after a 65 second delay.
6. Slowly lower the cooling temperature until the unit starts. The compressor, blower and fan should now be operating. Allow the unit to run 10 minutes, make sure cool air is being supplied by the unit.
7. Turn the temperature setting to the highest position, stopping the unit. The indoor blower will continue to run for 65 seconds.
8. Turn the thermostat system switch to "OFF" and disconnect all power when servicing the unit.

 **WARNING**

HIGH VOLTAGE!
DISCONNECT ALL POWER BEFORE SERVICING OR INSTALLING THIS UNIT. MULTIPLE POWER SOURCES MAY BE PRESENT. FAILURE TO DO SO MAY CAUSE PROPERTY DAMAGE, PERSONAL INJURY OR DEATH.



HEAT PUMP START-UP PROCEDURE

9. Check the cooling mode for the heat pump in the same manner as above. The reversing valve is energized when the thermostat is placed in the cooling position. A clicking sound should be noticeable from the reversing valve. By lowering the temperature setting to call for cooling, the contractor is energized. The compressor, blower and fan should then be running. After the cooling mode is checked out, turn the thermostat system switch to "OFF".
10. Turn the thermostat system switch to "HEAT" and fan switch to "AUTO".

11. Slowly raise the heating temperature setting. When the heating first stage makes contact, stop raising the temperature setting. The compressor, blower and fan should now be running with the reversing valve in the de-energized (heating) position. After giving the unit time to settle out, make sure the unit is supplying heated air.

12. If the outdoor ambient is above 80°F, the unit may trip on its high pressure cut out when on heating. The compressor should stop. The heating cycle must be thoroughly checked, so postpone the test to another day when conditions are more suitable but-DO NOT FAIL TO TEST.

If the outdoor ambient is low and the unit operates properly on the heating cycle, you may check the pressure cutout operation by blocking off the indoor return air until the unit trips.

13. If unit operates properly in the heating cycle, raise the temperature setting until the heating second stage makes contact. Supplemental resistance heat, if installed should now come on. Make sure it operates properly.

NOTE: If outdoor thermostats are installed the outdoor ambient must be below the set point of these thermostats for the heaters to operate. It may be necessary to jumper these thermostats to check heater operation if outdoor ambient is mild.

14. For thermostats with emergency heat switch, return to step 11. The emergency heat switch is located at the bottom of the thermostat. Move the switch to emergency heat. The heat pump will stop, the blower will continue to run, all heaters will come on and the thermostat emergency heat light will come on.

15. If checking the unit in the wintertime, when the outdoor coil is cold enough to actuate the defrost control, observe at least one defrost cycle to make sure the unit defrosts completely.

FINAL SYSTEM CHECKS

16. Check to see if all supply and return air grilles are adjusted and the air distribution system is balanced for the best compromise between heating and cooling.

17. Check for air leaks in the ductwork. See Sections on **Air Flow Adjustments**.

18. Make sure the unit is free of “rattles”, and the tubing in the unit is free from excessive vibration. Also make sure tubes or lines are not rubbing against each other or sheet metal surfaces or edges. If so, correct the trouble.

19. Set the thermostat at the appropriate setting for cooling and heating or automatic changeover for normal use.

20. Be sure the Owner is instructed on the unit operation, filter, servicing, correct thermostat operation, etc.

REFRIGERATION PERFORMANCE CHECK

Under normal summertime (full load) operating conditions, superheat should be between 8°F and 12°F and sub-cooling measured at the condenser outlet should be 15°F (nominal). A 25°F to 35°F temperature difference should exist between the entering condenser air and the temperature corresponding to the compressor saturated discharge pressure. Check that compressor RLA corresponds to values shown in Appendix C. RLA draw can be much lower than values listed at low load conditions and low ambient condensing temperatures. Values in Appendix C can slightly exceed at high load conditions and high ambient condensing temperatures.

HEAT PUMP OPERATION

COOLING CYCLE

When the heat pump is in the cooling cycle, it operates exactly as a Summer Air Conditioner unit. In this mode, all the charts and data for service that apply to summer air conditioning apply to the heat pump. Most apply on the heating cycle except that “condenser” becomes “evaporator”, “evaporator” becomes “condenser”, “cooling” becomes “heating”.

HEATING CYCLE

The heat pump operates in the heating cycle by redirecting refrigerant flow through the refrigerant circuit external to the compressor. This is accomplished with through the reversing valve. Hot discharge vapor from the compressor is directed to the indoor coil (evaporator on the cooling cycle) where the heat is removed, and the vapor condenses to liquid. It then goes through the expansion device to the outdoor coil (condenser on the cooling cycle) where the liquid is evaporated, and the vapor goes to the compressor.

When the solenoid valve coil is operated either from heating to cooling or vice versa, the piston in the reversing valve to the low pressure (high pressure) reverse positions in the reversing valve.

The following figures show a schematic of a heat pump on the cooling cycle and the heating cycle. In addition to a reversing valve, a heat pump is equipped with an expansion device and check valve for the indoor coil, and similar equipment for the outdoor coil. It is also provided with a defrost control system.

The expansion devices are flowrator distributors and perform the same function on the heating cycle as on the cooling cycle. The flowrator distributors also act as check valves to allow for the reverse of refrigerant flow.

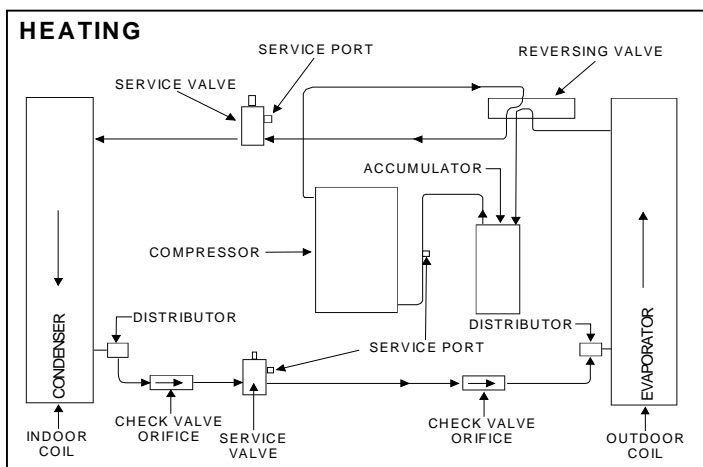
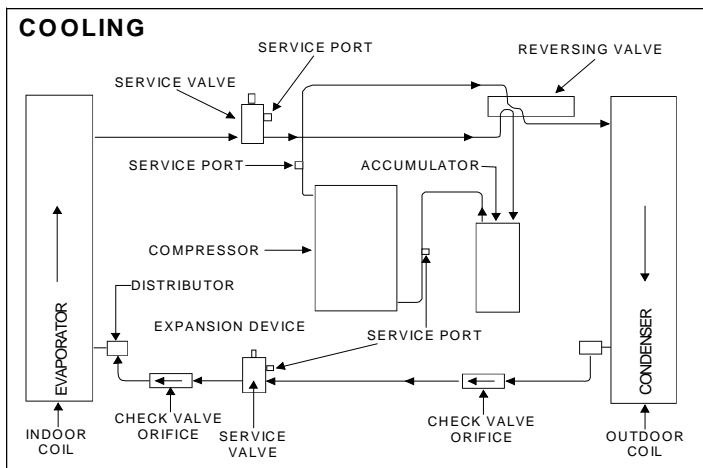

When the heat pump is on the heating cycle, the outdoor coil is functioning as an evaporator. The temperature of the refrigerant in the outdoor coil must be below the temperature of the outdoor air in order to extract heat from the air. Thus, the greater the difference in the outdoor temperature and the outdoor coil temperature, the greater the heating capacity of the heat pump. This phenomenon is a characteristic of a heat pump. It is a good practice to provide supplementary heat for all heat pump installations in areas where the temperature drops below 45° F. It is also a good practice to provide sufficient supplementary heat to handle the entire heating requirement should there be a component failure of the heat pump, such as a compressor, or refrigerant leak, etc.

Since the temperature of the refrigerant in the outdoor coil on the heating cycle is generally below freezing point, frost forms on the surfaces of the outdoor coil under certain weather conditions of temperature and relative humidity. Therefore, it is necessary to reverse the flow of the refrigerant to provide hot gas in the outdoor coil to melt the frost accumulation. This is accomplished by reversing the heat pump to the cooling cycle. At the same time, the outdoor fan stops to hasten the temperature rise of the outdoor coil and lessen the time required for defrosting. The indoor blower continues to run and the supplementary heaters are energized.

DEFROST CONTROL

During operation the power to the circuit board is controlled by a temperature sensor, which is clamped to a feeder tube entering the outdoor coil. Defrost timing periods of 30, 60 and 90 minutes may be selected by setting the circuit board jumper to 30, 60 and 90 respectively. Accumulation of time for the timing period selected starts when the sensor closes (approximately 31° F), and when the wall thermostat calls for heat. At the end of the timing period, the unit's defrost cycle will be initiated provided the sensor remains closed. When the sensor opens (approximately 75° F), the defrost cycle is terminated and the timing period is reset. If the defrost cycle is not terminated due to the sensor temperature, a twelve minute override interrupts the unit's defrost period.

AIR FLOW ADJUSTMENTS

The drive on the supply fan is typically set in the middle of the RPM range. The drive motor sheave pitch diameter is field adjustable for the required airflow. Refer to "Drive Adjustments" section below.

When the final adjustments are complete, the current draw of the motor should be checked and compared to the full load current rating of the motor. The amperage must not exceed the service factor stamped on the motor nameplate. The total airflow must not be less than that required for operation of the electric heaters or the furnace.

If an economizer is installed, check the unit operating balance with the economizer at full outside air and at minimum outside air. Upon completion of the air flow balancing, we recommend replacing the variable pitched motor sheave with a properly-sized fixed sheave. A matching fixed sheave will provide longer belt and bearing life and vibration free operation. Initially, it is best to have a variable pitched motor sheave for the purpose of airflow balancing, but once the balance has been achieved, fixed sheaves maintain alignment and minimize vibration more effectively. For direct drive units, move green wire for fan.

NOTE: Never run CFM below 350 CFM per ton, evaporator freezing or poor unit performance is possible.

PSC MOTOR

Adjust the CFM for the unit by changing the speed tap of the indoor blower motor at the EBTDR "com" connection with the one of the speed taps on "M1" or "M2" (Black-High Speed, Blue-Medium Speed, Red-Low Speed).

X-13 MOTOR

Adjust the CFM for the unit by changing the position of the low voltage leads on the motor terminal block. Green is for Fan Only. Yellow is for Cooling and Heat Pump Heating. Refer to Appendix A for blower performance at each speed tap.

NOTE: If more than one lead is energized simultaneously, the motor will run at the higher speed.

DRIVE ADJUSTMENTS MOTOR SHEAVE ADJUSTMENTS

VL, VM, & 2VP VARIABLE PITCH KEY TYPE MOTOR SHEAVES

The driving and driven motor sheaves should be in alignment with each other and the shafts parallel.

VL & VM SHEAVES ADJUSTMENT

1. Loosen set screw "B" using a 5/32" Allen key.
2. Making half or full turns from closed position, adjust sheave pitch diameter for desired speed. **DO NOT OPEN MORE THAN FIVE FULL TURNS.**
3. Tighten set screw "B" securely over flat.
4. Carefully put on belts and adjust belt tension. **DO NOT FORCE BELTS OVER GROOVES.**
5. Ensure all keys are in place and the set screws tight before starting drive. Recheck set screws and belt tension after 24 hours service.

NOTE: Future adjustments should be made by loosening the belt tension and increasing or decreasing the pitch diameter of the sheave by half or full turns as required. Readjust belt tension before starting drive.

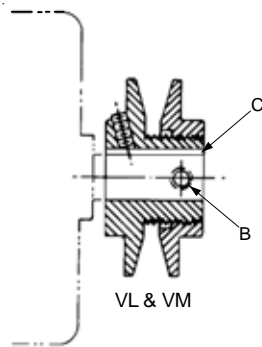

SHEAVE DIAGRAM

NOTE: Do not operate sheave with flange projecting beyond the hub end.

MAINTENANCE

WARNING

HIGH VOLTAGE!
DISCONNECT ALL POWER BEFORE SERVICING OR INSTALLING THIS UNIT. MULTIPLE POWER SOURCES MAY BE PRESENT. FAILURE TO DO SO MAY CAUSE PROPERTY DAMAGE, PERSONAL INJURY OR DEATH.



WARNING

TO PREVENT PERSONAL INJURY OR DEATH DUE TO IMPROPER INSTALLATION, ADJUSTMENT, ALTERATION, SERVICE OR MAINTENANCE, REFER TO THIS MANUAL. FOR ADDITIONAL ASSISTANCE OR INFORMATION, CONSULT A QUALIFIED INSTALLER, SERVICE AGENCY OR THE GAS SUPPLIER.

CAUTION

SHEET METAL PARTS, SCREWS, CLIPS AND SIMILAR ITEMS INHERENTLY HAVE SHARP EDGES, AND IT IS NECESSARY THAT THE INSTALLER AND SERVICE PERSONNEL EXERCISE CAUTION.

The Self Contained Packaged Air Conditioner and Heat Pump should operate for many years without excessive service calls if the unit is installed properly. However it is recommended that the homeowner inspect the unit before a seasonal start up. The coils should be free of debris so adequate airflow is achieved. The return and supply registers should be free of any obstructions. The filters should be cleaned or replaced. These few steps will help to keep the product up time to a maximum. The Service section that follows should help in identifying problems if the unit does not operate properly.

FILTERS

CAUTION

TO PREVENT PROPERTY DAMAGE DUE TO FIRE AND LOSS OF EQUIPMENT EFFICIENCY OR EQUIPMENT DAMAGE DUE TO DUST AND LINT BUILD UP ON INTERNAL PARTS, NEVER OPERATE UNIT WITHOUT AN AIR FILTER INSTALLED IN THE RETURN AIR SYSTEM.

Every application may require a different frequency of replacement of dirty filters. Filters must be replaced at least every three (3) months during operating seasons.

Dirty filters are the most common cause of inadequate heating or cooling performance. Filter inspection should be made at least every two months; more often if necessary because of local conditions and usage.

Dirty throwaway filters should be discarded and replaced with a new, clean filter.

Disposable return air filters are supplied with this unit. See the unit Specification Sheet or Technical Manual for the correct size and part number. To remove the filters, remove the filter access panel on return side of the unit.

CABINET FINISH MAINTENANCE

Use a fine grade automotive wax on the cabinet finish to maintain the finish's original high luster. This is especially important in installations with extended periods of direct sunlight.

CLEAN OUTSIDE COIL (QUALIFIED SERVICER ONLY)

The coil with the outside air flowing over it should be inspected annually and cleaned as frequently as necessary to keep the finned areas free of lint, hair and debris.

CONDENSER, EVAPORATOR, AND INDUCED DRAFT MOTORS

Bearings on the air circulating blower motor, condenser motor and the combustion fan motor are permanently lubricated. No additional oiling is required.

LUBRICATION

The fan shaft bearings, the 1 to 2 HP supply fan motors the condenser fan motors and compressors are permanently lubricated.

FUNCTIONAL PARTS

Refer to the unit Parts Catalog for a list of functional parts. Parts are available from your distributor.

SERVICE

THE FOLLOWING INFORMATION IS FOR USE BY QUALIFIED SERVICE AGENCY ONLY: OTHERS SHOULD NOT ATTEMPT TO SERVICE THIS EQUIPMENT.

Common Causes of Unsatisfactory Operation of Heat Pump on the Heating Cycle.

INADEQUATE AIR VOLUME THROUGH INDOOR COIL

When a heat pump is in the heating cycle, the indoor coil is functioning as a condenser. The return air filter must always be clean, and sufficient air volume must pass through the indoor coil to prevent excessive discharge pressure, and high pressure cut out.

OUTSIDE AIR INTO RETURN DUCT

Do not introduce cold outside air into the return duct of a heat pump installation. Do not allow air entering the indoor coil to drop below 65° F. Air below this temperature will cause low discharge pressure, thus low suction pressure, and excessive defrost cycling resulting in low heating output. It may also cause false defrosting.

UNDERCHARGE

An undercharged heat pump on the heating cycle will cause low discharge pressure resulting in low suction pressure and frost accumulation on the outdoor coil.

POOR "TERMINATING" SENSOR CONTACT

The unit's defrost terminating sensor must make good thermal contact with the outdoor coil tubing. Poor contact may not terminate the unit's defrost cycle quickly enough to prevent the unit from cutting out on high discharge pressure.

MALFUNCTIONING REVERSING VALVE - THIS MAY BE DUE TO:

1. **Solenoid not energized** - In order to determine if the solenoid is energized, touch the nut that holds the solenoid cover in place with a screwdriver. If the nut magnetically holds the screwdriver, the solenoid is energized and the unit is in the cooling cycle.
2. **No voltage at unit's solenoid** - Check unit voltage. If no voltage, check wiring circuit.
3. **Valve will not shift:**
 - a. **Undercharged** - check for leaks;
 - b. **Valve Body Damaged** - Replace valve;
 - c. **Unit Properly Charged** - If it is on the heating cycle, raise the discharge pressure by restricting airflow through the indoor coil. If the valve does not shift, tap it **lightly** on both ends with a screwdriver handle. **DO NOT TAP THE VALVE BODY.** If the unit is on the cooling cycle, raise the discharge pressure by restricting airflow through the outdoor coil. If the valve does not shift after the above attempts, cut the unit off and wait until the discharge and suction pressure equalize, and repeat above steps. If the valve does not shift, replace it.

APPENDIX A BLOWER PERFORMANCE TABLES DIRECT DRIVE

STANDARD DOWN SHOT AND HORIZONTAL

CPC/H036 DIRECT DRIVE DOWN SHOT

SPEED TAP	EXTERNAL STATIC PRESSURE (ESP) in w.c.	STANDARD CFM	AMPS	WATTS	RPM
LOW	0.10	1287	1.66	350	770
	0.20	1233	1.63	342	815
	0.30	1176	1.59	332	858
	0.40	1107	1.55	320	891
	0.50	1044	1.51	312	924
	0.60	965	1.45	296	957
MED	0.10	1476	2.08	446	866
	0.20	1421	2.03	432	885
	0.30	1334	1.96	414	918
	0.40	1255	1.90	396	945
	0.50	1180	1.84	386	971
	0.60	1085	1.78	368	990
	0.70	964	1.70	344	1023
HIGH	0.30	1455	2.31	490	962
	0.40	1367	2.25	476	984
	0.50	1277	2.16	454	1006
	0.60	1180	2.09	438	1025
	0.70	1080	2.02	418	1039
	0.80	922	1.90	386	1067

CPC/H036 DIRECT DRIVE HORIZONTAL

SPEED TAP	EXTERNAL STATIC PRESSURE (ESP) in w.c.	STANDARD CFM	AMPS	WATTS	RPM
LOW	0.10	1296	1.67	356	764
	0.20	1245	1.60	334	830
	0.30	1174	1.56	325	861
	0.40	1103	1.52	316	891
	0.50	1013	1.46	300	935
MED	0.10	1502	2.10	456	836
	0.20	1449	2.06	444	864
	0.30	1396	2.02	432	891
	0.40	1335	1.97	418	916
	0.50	1273	1.91	404	940
	0.60	1153	1.83	380	973
	0.70	996	1.71	346	1017
HIGH	0.20	1516	2.36	506	940
	0.30	1454	2.31	496	960
	0.40	1392	2.26	486	979
	0.50	1273	2.17	458	1006
	0.60	1183	2.09	441	1023
	0.70	1092	2.02	424	1039
	0.80	920	1.90	390	1067

NOTES:

Tables represent dry coil without filter, to compensate for filter add 0.08" to measured E.S.P. SCFM correction for wet coil = 4%.

3 Ton models are shipped from the factory with speed tap set on LOW.

APPENDIX A BLOWER PERFORMANCE TABLES

DIRECT DRIVE

STANDARD DOWN SHOT AND HORIZONTAL

CPC/H048 DIRECT DRIVE DOWN SHOT

SPEED TAP	EXTERNAL STATIC PRESSURE (ESP) in w.c.	STANDARD CFM	AMPS	WATTS	RPM
LOW	0.10	1602	2.48	528	835
	0.20	1538	2.37	506	878
	0.30	1474	2.26	484	921
	0.40	1390	2.15	460	950
	0.50	1306	2.04	436	979
MED	0.10	1805	2.84	620	935
	0.20	1704	2.71	590	967
	0.30	1625	2.59	558	990
	0.40	1549	2.47	540	1012
	0.50	1437	2.38	516	1030
	0.60	1301	2.23	480	1050
HIGH	0.70	1158	2.09	444	1072
	0.10	1971	3.22	706	968
	0.20	1828	3.03	664	998
	0.30	1744	2.94	632	1017
	0.40	1628	2.80	606	1034
	0.50	1510	2.69	582	1050
	0.60	1402	2.57	552	1067

CPC/H048 DIRECT DRIVE HORIZONTAL

SPEED TAP	EXTERNAL STATIC PRESSURE (ESP) in w.c.	STANDARD CFM	AMPS	WATTS	RPM
LOW	0.10	1622	2.54	539	809
	0.20	1558	2.43	517	852
	0.30	1494	2.32	495	895
	0.40	1410	2.21	471	924
	0.50	1326	2.10	447	953
MED	0.10	1861	3.11	670	886
	0.20	1733	2.78	606	918
	0.30	1639	2.64	568	960
	0.40	1564	2.51	542	984
	0.50	1434	2.35	508	1017
	0.60	1320	2.25	482	1039
HIGH	0.70	1156	2.08	446	1067
	0.10	1984	3.34	734	949
	0.20	1883	3.18	694	977
	0.30	1770	3.03	654	1001
	0.40	1656	2.87	620	1027
	0.50	1540	2.76	590	1044
	0.60	1415	2.62	558	1061

NOTES:

Tables represent dry coil without filter, to compensate for filter add 0.08" to measured E.S.P. SCFM correction for wet coil = 4 %.

4 Ton models are shipped from the factory with speed tap set on MED.

APPENDIX A BLOWER PERFORMANCE TABLES

DIRECT DRIVE

STANDARD CPC/H060 DOWN SHOT

CPC/H060 DIRECT DRIVE DOWN SHOT

SPEED TAP	EXTERNAL STATIC PRESSURE (ESP) in w.c.	STANDARD CFM	AMPS	WATTS	RPM
T1	0.10	1334	1.65	180	627
	0.20	1286	1.75	192	665
	0.30	1212	1.83	202	715
	0.40	1144	1.94	216	759
	0.50	1077	1.99	222	792
	0.60	1039	2.10	238	830
	0.70	953	2.17	248	874
	0.80	904	2.27	258	913
	0.90	825	2.30	266	940
T2	0.10	1512	2.12	240	682
	0.20	1469	2.24	254	720
	0.30	1397	2.31	264	759
	0.40	1333	2.44	282	803
	0.50	1285	2.54	296	836
	0.60	1221	2.59	304	874
	0.70	1173	2.72	322	913
	0.80	1118	2.77	328	946
	0.90	1049	2.90	344	984
T3	0.10	2053	4.27	540	869
	0.20	2014	4.39	558	896
	0.30	1999	4.60	576	929
	0.40	1947	4.68	588	957
	0.50	1897	4.79	608	989
	0.60	1857	4.87	620	1012
	0.70	1763	4.99	640	1050
	0.80	1741	5.06	650	1072
	0.90	1669	5.19	668	1105
T4	0.10	2137	4.95	634	913
	0.20	2093	5.07	652	940
	0.30	2095	5.19	670	962
	0.40	2026	5.28	682	990
	0.50	1980	5.40	698	1018
	0.60	1961	5.49	720	1039
	0.70	1914	5.58	732	1072
	0.80	1845	5.70	742	1100
	0.90	1766	5.69	740	1127
T5	0.10	2299	5.70	742	942
	0.20	2233	5.80	748	969
	0.30	2217	5.90	768	990
	0.40	2157	6.07	786	1018
	0.50	2131	6.12	804	1045
	0.60	2060	6.21	816	1073
	0.70	2015	6.30	820	1095
	0.80	1940	6.27	816	1111
	0.90	1862	6.13	790	1128

NOTES:

Tables represent dry coil without filter, to compensate for filter add 0.08" to measured E.S.P. SCFM correction for wet coil = 4%. 5 Ton models are shipped from the factory with speed tap set on T4.

APPENDIX A BLOWER PERFORMANCE TABLES

DIRECT DRIVE

STANDARD CPC/H060 HORIZONTAL

CPC/H060 DIRECT DRIVE HORIZONTAL

SPEED TAP	EXTERNAL STATIC PRESSURE (ESP) in w.c.	STANDARD CFM	AMPS	WATTS	RPM
T1	0.10	1355	1.57	174	599
	0.20	1281	1.66	182	651
	0.30	1235	1.76	196	693
	0.40	1168	1.81	202	726
	0.50	1118	1.94	218	775
	0.60	1049	2.03	232	819
	0.70	982	2.10	240	858
	0.80	922	2.14	246	885
	0.90	871	2.25	260	927
T2	0.10	1544	2.04	234	660
	0.20	1490	2.17	250	704
	0.30	1427	2.25	260	742
	0.40	1370	2.35	276	781
	0.50	1319	2.42	282	809
	0.60	1274	2.52	296	849
	0.70	1210	2.62	316	891
	0.80	1137	2.73	326	935
	0.90	1106	2.77	336	957
T3	0.10	2099	4.13	516	825
	0.20	2068	4.25	536	852
	0.30	2029	4.37	552	885
	0.40	1971	4.48	568	913
	0.50	1911	4.61	586	950
	0.60	1876	4.73	604	973
	0.70	1821	4.86	622	1012
	0.80	1792	4.91	630	1028
	0.90	1740	5.03	648	1067
T4	0.10	2233	4.76	608	863
	0.20	2168	4.91	628	896
	0.30	2125	5.02	640	924
	0.40	2070	5.14	660	951
	0.50	2050	5.27	678	979
	0.60	1980	5.41	696	1012
	0.70	1954	5.47	704	1034
	0.80	1893	5.60	724	1067
	0.90	1852	5.70	736	1089
T5	0.10	2322	5.44	710	904
	0.20	2294	5.55	726	934
	0.30	2254	5.68	742	958
	0.40	2201	5.80	766	990
	0.50	2147	5.93	782	1017
	0.60	2117	6.01	788	1039
	0.70	2081	6.12	808	1060
	0.80	2017	6.22	822	1094
	0.90	1932	6.10	804	1111

NOTES:

Tables represent dry coil without filter, to compensate for filter add 0.08" to measured E.S.P. SCFM correction for wet coil = 4 %.

APPENDIX A BLOWER PERFORMANCE TABLES

BELT DRIVE

STANDARD DOWN SHOT

CPC/H036 STANDARD BELT DRIVE DOWN SHOT

ESP, In H ₂ O	TURNS OPEN											
	0		1		2		3		4		5	
	CFM	BHP	CFM	BHP	CFM	BHP	CFM	BHP	CFM	BHP	CFM	BHP
0.2									1424	0.30	1239	0.23
0.4					1520	0.39	1292	0.29	1073	0.22	779	0.14
0.6			1439	0.40	1192	0.30	944	0.21	619	0.12		
0.8	1350	0.42	1101	0.31	864	0.22						
1.0	1028	0.31	729	0.21								
1.2	675	0.20										

CPC/H048 STANDARD BELT DRIVE DOWN SHOT

ESP, In H ₂ O	TURNS OPEN											
	0		1		2		3		4		5	
	CFM	BHP	CFM	BHP	CFM	BHP	CFM	BHP	CFM	BHP	CFM	BHP
0.2							2129	0.64	1795	0.47	1550	0.35
0.4					1994	0.65	1701	0.49	1433	0.36	1163	0.22
0.6			1905	0.67	1606	0.50	1326	0.36	1025	0.22		
0.8	1808	0.69	1565	0.54	1216	0.36						
1.0	1473	0.55	1137	0.32								
1.2	1103	0.41										

CPC/H060 STANDARD BELT DRIVE DOWN SHOT

ESP, In H ₂ O	TURNS OPEN											
	0		1		2		3		4		5	
	CFM	BHP	CFM	BHP	CFM	BHP	CFM	BHP	CFM	BHP	CFM	BHP
0.2					2579	1.01	2368	0.85	2175	0.691	1961	0.55
0.4			2513	1.05	2318	0.89	2089	0.73	1906	0.59	1666	0.44
0.6	2514	1.14	2276	0.94	2045	0.77	1797	0.60	1604	0.47		
0.8	2261	1.01	2017	0.82	1760	0.63						
1.0	1989	0.87	1730	0.68								
1.2	1695	0.72										

CPC/H072 STANDARD BELT DRIVE DOWN SHOT

ESP, In H ₂ O	TURNS OPEN											
	0		1		2		3		4		5	
	CFM	BHP	CFM	BHP	CFM	BHP	CFM	BHP	CFM	BHP	CFM	BHP
0.2					2771	1.27	2567	1.05	2421	0.88	2220	0.71
0.4			2753	1.38	2573	1.15	2382	0.95	2186	0.77	1980	0.61
0.6	2655	1.42	2548	1.24	2360	1.02	2119	0.81	1934	0.65		
0.8	2470	1.30	2331	1.11	2111	0.89	1868	0.69				
1.0	2296	1.18	2078	0.96	1840	0.75						
1.2	2040	1.02										

NOTES:

Tables represent dry coil without filter, to compensate for filter add 0.08" to measured E.S.P.
SCFM correction for wet coil = 4 %.

APPENDIX A BLOWER PERFORMANCE TABLES

BELT DRIVE

HIGH STATIC DOWN SHOT

CPC/H036 HIGH STATIC BELT DRIVE DOWN SHOT

ESP, In H ₂ O	TURNS OPEN											
	0		1		2		3		4		5	
	CFM	BHP	CFM	BHP	CFM	BHP	CFM	BHP	CFM	BHP	CFM	BHP
0.6							1692	0.54	1449	0.41	1173	0.29
0.8					1678	0.58	1397	0.44	1107	0.31	854	0.21
1.0			1681	0.65	1381	0.49	1078	0.34	794	0.22		
1.2	1681	0.71	1362	0.54	1062	0.39						
1.4	1362	0.60	1066	0.44								
1.6	1066	0.50	789	0.34								
1.8	789	0.40										

CPC/H048 HIGH STATIC BELT DRIVE DOWN SHOT

ESP, In H ₂ O	TURNS OPEN											
	0		1		2		3		4		5	
	CFM	BHP	CFM	BHP	CFM	BHP	CFM	BHP	CFM	BHP	CFM	BHP
0.6							2194	0.85	1886	0.66	1580	0.49
0.8					2113	0.86	1832	0.70	1526	0.52	1219	0.37
1.0			2182	0.98	1776	0.73	1472	0.55	1166	0.39		
1.2	2053	1.00	1780	0.80	1440	0.59	1111	0.40				
1.4	1759	0.86	1421	0.64	1104	0.46						
1.6	1442	0.72	1095	0.50								
1.8	1095	0.56										

CPC/H060 HIGH STATIC BELT DRIVE DOWN SHOT

ESP, In H ₂ O	TURNS OPEN											
	0		1		2		3		4		5	
	CFM	BHP	CFM	BHP	CFM	BHP	CFM	BHP	CFM	BHP	CFM	BHP
0.6									2331	1.01	2072	0.80
0.8							2324	1.10	2059	0.87	1791	0.66
1.0					2350	1.21	2058	0.95	1774	0.72		
1.2			2367	1.33	2086	1.06	1776	0.79				
1.4	2404	1.45	2111	1.17	1805	0.89						
1.6	2136	1.28	1835	0.99								
1.8	1868	1.10										

CPC/H072 HIGH STATIC BELT DRIVE DOWN SHOT

ESP, In H ₂ O	TURNS OPEN											
	0		1		2		3		4		5	
	CFM	BHP	CFM	BHP	CFM	BHP	CFM	BHP	CFM	BHP	CFM	BHP
0.6					2793	1.64	2603	1.39	2450	1.182	2270	0.97
0.8			2903	1.87	2696	1.57	2369	1.23	2236	1.05	1987	0.82
1.0	2776	1.86	2683	1.69	2445	1.38	2196	1.12	1968	0.90		
1.2	2599	1.71	2539	1.57	2310	1.29	1932	0.96				
1.4	2424	1.57	2305	1.40	2032	1.11						
1.6	2172	1.38	2017	1.19								
1.8	1953	1.22										

NOTES:

Tables represent dry coil without filter, to compensate for filter add 0.08" to measured E.S.P.
SCFM correction for wet coil = 4 %.

APPENDIX A BLOWER PERFORMANCE TABLES

BELT DRIVE

STANDARD HORIZONTAL

CPC/H036 STANDARD BELT DRIVE HORIZONTAL

ESP, In H ₂ O	TURNS OPEN											
	0		1		2		3		4		5	
	CFM	BHP	CFM	BHP	CFM	BHP	CFM	BHP	CFM	BHP	CFM	BHP
0.2									1658	0.35	1489	0.28
0.4							1560	0.36	1339	0.28	1129	0.21
0.6			1682	0.47	1436	0.36	1196	0.27	949	0.19		
0.8	1581	0.50	1354	0.38	1096	0.28	828	0.18				
1.0	1266	0.39	994	0.28	756	0.19						
1.2	923	0.28										

CPC/H048 STANDARD BELT DRIVE HORIZONTAL

ESP, In H ₂ O	TURNS OPEN											
	0		1		2		3		4		5	
	CFM	BHP	CFM	BHP	CFM	BHP	CFM	BHP	CFM	BHP	CFM	BHP
0.2									1943	0.52	1714	0.40
0.4					2187	0.72	1876	0.55	1566	0.40	1270	0.26
0.6			2044	0.72	1761	0.56	1444	0.40	1136	0.26		
0.8	1947	0.74	1704	0.59	1335	0.40						
1.0	1598	0.60	1275	0.36								
1.1	1208	0.45										

CPC/H060 STANDARD BELT DRIVE HORIZONTAL

ESP, In H ₂ O	TURNS OPEN											
	0		1		2		3		4		5	
	CFM	BHP	CFM	BHP	CFM	BHP	CFM	BHP	CFM	BHP	CFM	BHP
0.2									2420	0.79	2198	0.64
0.4					2605	1.02	2358	0.84	2133	0.67	1874	0.52
0.6			2526	1.06	2300	0.88	2026	0.70	1806	0.55		
0.8	2529	1.15	2252	0.93	1975	0.73	1670	0.54				
1.0	2233	0.99	1943	0.78	1628	0.57						
1.2	1907	0.83	1582	0.61								

CPC/H072 STANDARD BELT DRIVE HORIZONTAL

ESP, In H ₂ O	TURNS OPEN											
	0		1		2		3		4		5	
	CFM	BHP	CFM	BHP	CFM	BHP	CFM	BHP	CFM	BHP	CFM	BHP
0.2							2784	1.30	2582	0.83	2411	0.79
0.4					2814	1.34	2620	1.19	2342	0.72	2105	0.66
0.6			2665	1.34	2583	1.19	2398	1.06	2103	0.62	1902	0.57
0.8	2689	1.38	2492	1.22	2370	1.07	2142	0.91	1816	0.51		
1.0	2438	1.22	2275	1.09	2098	0.92	1883	0.78				
1.2	2250	1.10	1996	0.92								

NOTES:

Tables represent dry coil without filter, to compensate for filter add 0.08" to measured E.S.P.
SCFM correction for wet coil = 4 %.

APPENDIX A BLOWER PERFORMANCE TABLES

BELT DRIVE

HIGH STATIC HORIZONTAL

CPC/H036 HIGH STATIC BELT DRIVE HORIZONTAL

ESP, In H ₂ O	TURNS OPEN											
	0		1		2		3		4		5	
	CFM	BHP	CFM	BHP	CFM	BHP	CFM	BHP	CFM	BHP	CFM	BHP
0.6									1742	0.50	1431	0.36
0.8							1626	0.52	1357	0.39	1078	0.27
1					1611	0.56	1315	0.42	1011	0.28		
1.2			1605	0.62	1299	0.46	976	0.31				
1.4	1605	0.68	1281	0.51	959	0.35						
1.6	1281	0.57	981	0.41								
1.8	981	0.47										

CPC/H048 HIGH STATIC BELT DRIVE HORIZONTAL

ESP, In H ₂ O	TURNS OPEN											
	0		1		2		3		4		5	
	CFM	BHP	CFM	BHP	CFM	BHP	CFM	BHP	CFM	BHP	CFM	BHP
0.6									2056	0.72	1721	0.54
0.8							1996	0.77	1662	0.57	1328	0.40
1					1924	0.79	1603	0.61	1270	0.43		
1.2			1952	0.88	1559	0.64	1210	0.44				
1.4	1888	0.92	1543	0.70	1195	0.49						
1.6	1557	0.77	1180	0.54								
1.8	1192	0.60										

CPC/H060 HIGH STATIC BELT DRIVE HORIZONTAL

ESP, In H ₂ O	TURNS OPEN											
	0		1		2		3		4		5	
	CFM	BHP	CFM	BHP	CFM	BHP	CFM	BHP	CFM	BHP	CFM	BHP
0.6											2323	0.92
0.8									2315	1.00	2009	0.77
1							2308	1.09	1992	0.84	1666	0.60
1.2					2338	1.21	1992	0.92	1646	0.66		
1.4			2359	1.32	2025	1.02	1648	0.72				
1.6	2404	1.45	2056	1.13	1684	0.82						
1.8	2088	1.24	1722	0.92								

CPC/H072 HIGH STATIC BELT DRIVE HORIZONTAL

ESP, In H ₂ O	TURNS OPEN											
	0		1		2		3		4		5	
	CFM	BHP	CFM	BHP	CFM	BHP	CFM	BHP	CFM	BHP	CFM	BHP
0.6									2746	1.38	2515	1.12
0.8							2721	1.47	2494	1.21	2261	0.97
1					2689	1.56	2500	1.32	2255	1.06	1994	0.83
1.2			2752	1.74	2473	1.40	2252	1.15	1996	0.91		
1.4	2802	1.88	2487	1.53	2286	1.27	2037	1.02				
1.6	2553	1.67	2308	1.40	1997	1.08						
1.8	2355	1.51	2014	1.19								
2.0	2055	1.29										

NOTES:

Tables represent dry coil without filter, to compensate for filter add 0.08" to measured E.S.P.
SCFM correction for wet coil = 4 %.

APPENDIX B ELECTRICAL DATA

ELECTRICAL DATA

MODELS	VOLTAGE (NAMEPLATE)	VOLTAGE LIMITATION		COMPRESSOR			OUTDOOR FAN MOTOR			INDOOR MOTOR APPLICATION	INDOOR FAN MOTOR	
		MIN.	MAX.	QTY	RLA	LRA	QTY	HP	RLA		HP	FLA
3 TON	208/230-60-1	187	253	1	16.67	79	1	1/4	1.40	DD STD STATIC	1/3	2.5
	208/230-60-3	187	253	1	10.45	73.0	1	1/4	1.40	DD STD STATIC	1/3	2.5
										BD STD STATIC	1.0	3.8
	460-60-3	414	506	1	5.77	38.0	1	1/4	0.80	BD STD STATIC	1.0	1.9
575-60-3	518	633	1	3.8	37.0	1	1/4	0.60	BD STD STATIC	1.5	2.3	
4 TON	208/230-60-1	187	253	1	19.87	109	1	1/4	1.40	DD STD STATIC	1/2	2.9
	208/230-60-3	187	253	1	13.14	83.1	1	1/4	1.40	DD STD STATIC	1/2	2.9
										BD STD STATIC	1.0	3.8
	460-60-3	414	506	1	6.09	41.0	1	1/4	0.80	BD STD STATIC	1.0	1.9
575-60-3	518	633	1	4.4	33.0	1	1/4	0.60	BD STD STATIC	1.5	2.3	
5 TON	208/230-60-1	187	253	1	26.41	134	1	1/4	1.40	DD STD STATIC	1.0	7.6
	208/230-60-3	187	253	1	15.96	110.0	1	1/4	1.40	DD STD STATIC	1.0	7.6
										BD STD STATIC	1.0	3.8
	460-60-3	414	506	1	7.76	52.0	1	1/4	0.80	BD STD STATIC	1.0	1.9
575-60-3	518	633	1	5.71	38.9	1	1/4	0.60	BD STD STATIC	1.5	2.3	
6 TON	208/230-60-3	187	253	1	19	123	1	1/3	1.92	BD STD STATIC	1.5	5.0
	460-60-3	414	506	1	9.70	62.0	1	1/3	1.20	BD STD STATIC	1.5	2.5
	575-60-3	518	633	1	7.4	50.0	1	1/3	0.90	BD STD STATIC	1.5	2.3

APPENDIX B ELECTRICAL DATA

MINIMUM AIR FLOW FOR ELECTRIC HEAT

UNIT	HEATER KIT MODEL NUMBER	MINIMUM CFM
3 TON	EHK*-10	1250
	EHK*-15	1250
4 TON	EHK*-10	1300
	EHK*-15	1400
	EHK*-18	1400
5 TON	EHK*-10	1700
	EHK*-15	1700
	EHK*-20	1800
6 TON	EHK*-10	2100
	EHK*-15	2100
	EHK*-20	2100
	EHK*-25	2100



ATTENTION INSTALLING PERSONNEL

Use only the heater kit specified for each model as dictated by the table above.

APPENDIX C UNIT DIMENSIONS

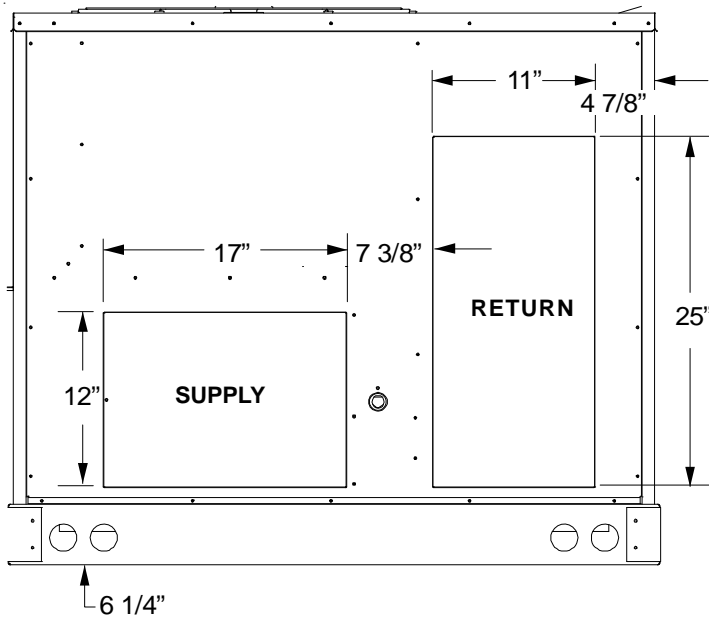
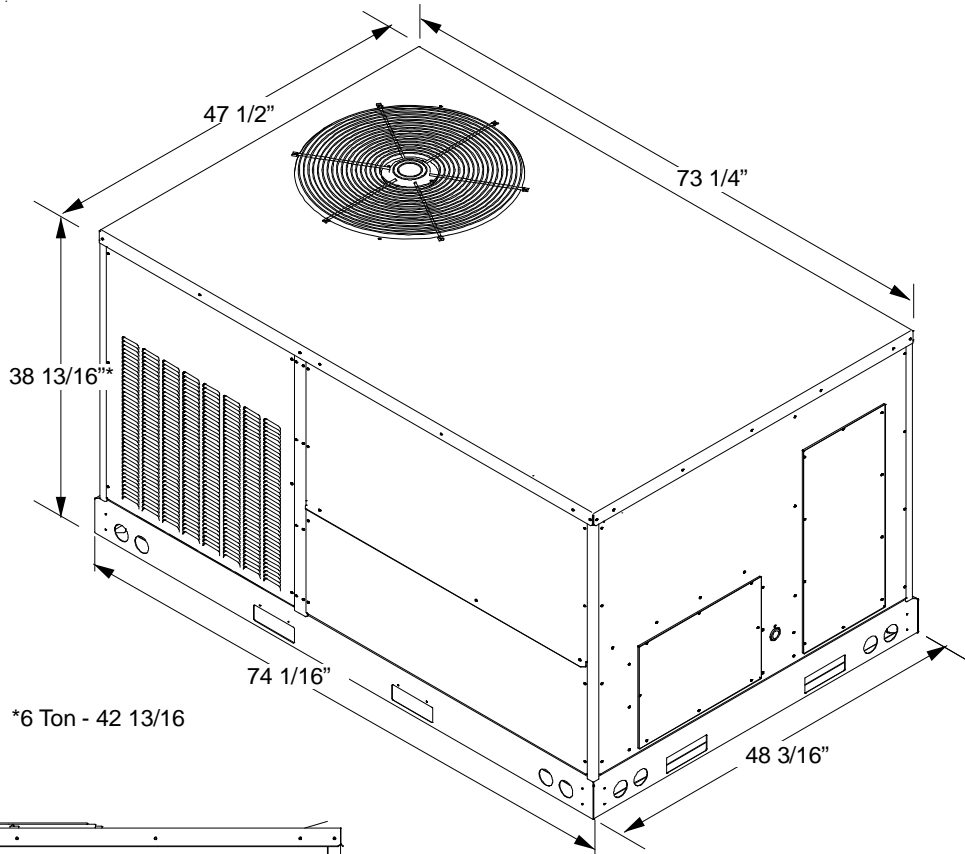

HORIZONTAL DISCHARGE

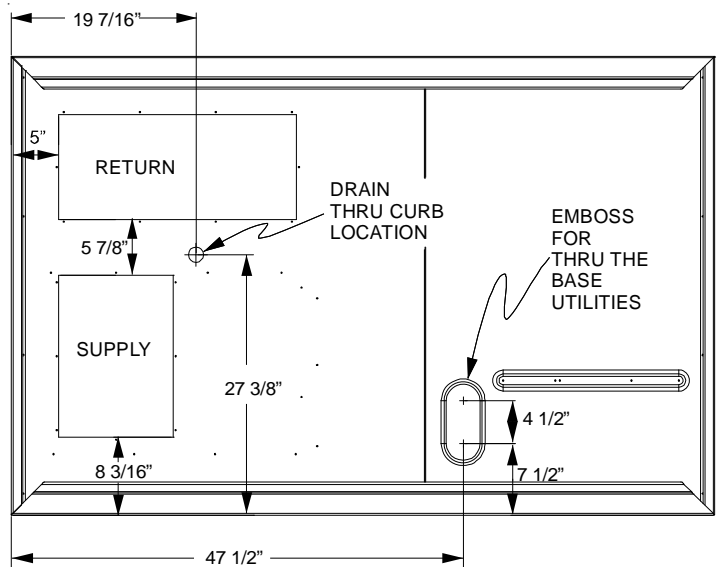

BOTTOM VIEW OF UNIT
VERTICAL DISCHARGE

NOTE

For horizontal discharge, remove the supply and return duct covers and place them over the vertical discharge return and supply openings. Install with insulation facing up, using the longer screws provided in the literature package.

Goodman Manufacturing Company, L.P.
5151 Felipe, Suite 500, Houston, TX 77056
www.goodmanmfg.com www.amana-hac.com
© 2010,2012 Goodman Manufacturing Company, L.P.